

# hydraulic piston cylinders UCJ6F

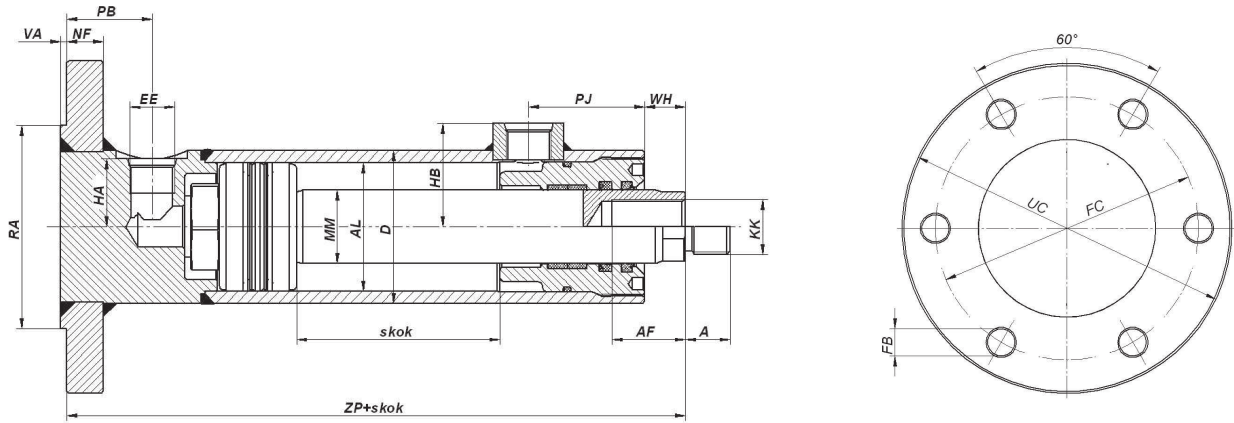

AL	40	50	63	80	100	125	140	160
<b>MM</b>	22	28	36	45	56	70	80	90
<b>A</b>	18	20	22	30	36	45	50	56
<b>AF</b>	22	30	36	45	50	63	75	85
<b>D</b>	50	60	75	95	120	145	165	185
<b>EE</b>	M16x1.5*	M16x1.5*	M22x1.5*	M27x2*	M33x2*	M33x2*	M33x2*	M33x2*
<b>FB</b>	9	11	13,5	17	22	22	26	26
<b>FC</b>	90	106	130	175	200	230	240	280
<b>HA</b>	22	27	34	43	66	69	80	107
<b>HB</b>	36	42	50	62	75	88	98	110
<b>KK</b>	M16x1.5	M22x1.5	M27x2	M33x2	M42x2	M48x2	M56x2	M64x2
<b>NF</b>	14	16	18	19	25	30	30	35
<b>PB</b>	34	41	46	55	62	65	60	85
<b>PJ</b>	48	47	59	67	67	82	87	99
<b>RA</b>	65	85	100	135	150	180	185	240
<b>UC</b>	110	130	160	210	240	280	288	340
<b>VA</b>	3	3	3	3	5	4	5	5
<b>WH</b>	10	15	15	18	21	32	20	50
<b>ZP</b>	159	178	205	245	284	306	341	374

Standardised pitch sequence: 100, 125, 160, 200, 250, 320, 400, 500, 630, 800, 1000, 1250, 1600, 2000

Piston pitch and piston rod diameters may be selected outside the typical sequence according to individual customer needs.

AL Piston diameters – 25, 32, 60, 70, 90, 110, 150, 180, 200 – provided upon special customer order.

\* oil connections according to PN-64/M-73101

PONAR Luban Sp. z o.o. reserves the right to implement design modifications not affecting cylinder casing.